

Elcometer PERFORMANCE Blast Machines have been designed to minimise pressure loss and maximise air flow - allowing you to blast for longer, reduce media costs and minimise downtime.

Rating Plate

Clear information on pressure ratings, UKCA and CE approval to both PED 2014/68EU and PE(s)R 2016.

Easy Access

Large inspection access wide enough for both arms.

Fast Flow Cones

45/90° cone to maximise abrasive flow rate.

Precision Media Valves

Enable finger tip adjustment allowing you to use less abrasive to cover the same area in less time.

High Flow Dish

Concave dish for easy refill and deflector plate for operator safety.

Easy to manoeuvre

Balanced design makes it easy to move on site.

High flow 1½" (38mm) Pipework

1½" (38mm) pipework throughout ensures efficient airflow and minimal pressure loss

1½" (38mm) Remote Control Valves

Minimises air flow loss and shuts the blast system down quickly and safely.

Moisture Separator

Prevents water and oil from entering the blast pot.



Flexible Pusher Line

Hard wearing flexible pusher line to maximise air flow.

The Elcometer Abrasive Blast Machine Range Comparison Summary

From small maintenance projects to large scale refurbishment contracts, from blasting small industrial parts to ballast tanks, or iron gates to bridges...

...whatever the scale of your project Elcometer blast equipment is engineered to last longer, work harder and perform better.

CONTRACTOR

174psi
(12bar)

1 1/4"
(32mm)

- Industry standard valves & RCV
 - 1 1/4" (32mm) pipework
- Great efficiency & productivity
 - 174psi (12bar)



1.41-7.06cu ft (40-200 litres)

174psi (12bar)

32mm (1 1/4")

UKCA & CE Approved

Standard Grit Valve (SGV)

Standard

Elcometer Engineered
Standard Mixer T

Standard

Elbow

Made in Great Britain

Capacity

Maximum Working Pressure (WP)

Pipework Diameter

UKCA & CE Approved to
PED 2014/68EU & PE(s)R 2016

Abrasive Media Valve

Valve Liner

Mixer T

Remote Control Valve

Exhaust T

Construction

PERFORMANCE

174psi
(12bar)

1 1/4"
(32mm)

- Elcometer engineered valves & RCV
 - 1 1/2" (38mm) high flow pipework
 - High efficiency & productivity
 - 174psi (12bar)
 - Ideal for all projects

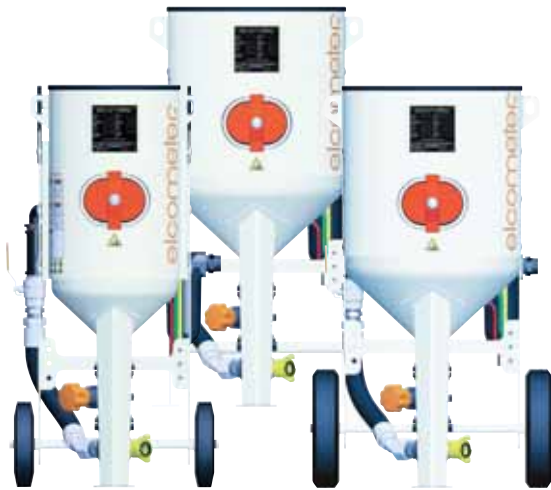

0.70-10.06cu ft (20-285 litres)

174psi (12bar)

38mm (1 1/2")

UKCA, CE & ASME Approved

Elcometer GV/AGV

elcoTOUGH™ Long Life Liner

Elcometer Engineered High Resistance
Long Life Mixer T

Elcometer Engineered

90° Reinforced Elbow
& Sacrificial Wear Plug

Made in Great Britain

PERFORMANCE HP

217psi
(15bar)

1 1/2"
(38mm)

- Elcometer engineered valves & RCV
 - 1 1/2" (38mm) high flow pipework
 - Ultimate efficiency & productivity
 - High pressure 217psi (15bar)
 - Ideal for large scale contracts
and long hose runs



3.53-10.06cu ft (100-285 litres)

217psi (15psi)

38mm (1 1/2")

UKCA & CE Approved

Elcometer GV/AGV

elcoTOUGH™ Long Life Liner

Elcometer Engineered High Resistance
Long Life Mixer T

Elcometer Engineered

90° Reinforced Elbow
& Sacrificial Wear Plug

Made in Great Britain

Elcometer **Performance**
Abrasive Blast Machines are
engineered to **work harder,**
last longer and **perform**
better



Productivity is a function of
pressure and air flow.

*"For every psi at the nozzle above
7bar (100psi) you get a 1.5% increase
in productivity."*

ENHANCE YOUR PERFORMANCE

Optimising the volume, speed and pressure of air to the nozzle results in greater blasting efficiency. Higher pressure and speed of air at the nozzle will also allow use of a larger nozzle size, resulting in faster blast area coverage, allowing you to cover more in less time.

Operating at more efficient blast pressures will also result in less abrasive usage thus **saving money and clean up time!**

■ Minimise Your Pressure Loss

The design of your blast machine together with your blast hose diameter, length, age, wear and quality can effect the pressure at the nozzle.

This is why we manufacture blast machines which have a maximum working pressure of either 174 or 217psi (12 or 15bar) and have been engineered for minimal pressure loss - so that you will always have the nozzle pressure you need to maximise your productivity.



■ Maximise Your Cubic Air Flow Per Minute

With an internal pipe diameter of 1½" (38mm) across our blast machines we have optimised the volumetric flow rate of air through the system every minute so that you can select a larger nozzle diameter, allowing you to blast more in less time.



■ Blast for Longer

Elcometer blast machines have a maximum working pressure of 174 or 217psi (12 or 15bar) allowing you to maintain the nozzle pressure over significantly longer lengths of hose, even as it wears.

■ Reduce Your Media Costs

Elcometer blast machines are designed to deliver the optimum pressure and flow rate at the nozzle, allowing you to use less abrasive to blast the same area to the same profile, saving you money.

Our abrasive media valves come with fingertip adjustment so that you can precisely control the media flow, even whilst blasting.



■ Reduce Your Maintenance

Elcometer's blast machines are engineered to be extremely durable so that parts last longer. Forcing abrasive through a high pressure system will, however, always create wear and tear so we have designed our machines to be easy and fast to maintain so that you can maximise your blast time.



■ Be In Control

Designed for precision control and minimal air flow loss, the Elcometer RCV4000 & RCV4000+ Remote Control Valves allow you to safely control a blast machine at the nozzle, fast.

ELCOMETER ENGINEERED

Every aspect of an Elcometer Blast Machine uses high quality components, manufactured to an industry leading specification and designed and engineered by Elcometer experts.



Heavy Duty Construction

1/4" (6mm) steel wall thickness, double weld seams & coated with a tough 2 pack epoxy multi-coat paint for corrosion protection.



High Flow Pipework & Valves

Large bore 1 1/2" (38mm) pipework throughout ensures efficient airflow and minimal pressure loss.

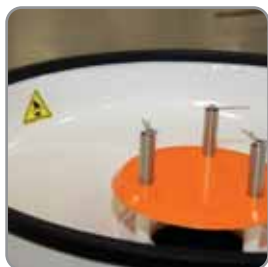

Concave Dishes

Our high flow concave dish comes complete with a deflector plate for fast filling & operator safety.



Fast Flow Cones

45/90° cone to maximise abrasive flow rate.



Remote Control Valves

Used with a deadman's handle, the 1 1/2" (38mm) remote control valve minimises air flow loss and shuts the blast system down quickly and safely.



Precision Metering Valves

Range of precision metering valves offer accurate control of your blast media, even whilst blasting.



Exhaust Manifolds

Hard working exhaust manifolds allow air to exhaust through the silencer quickly & safely, with minimum wear.



Moisture Separators

High performance moisture separator prevents water and oil from entering the blast pot.



Hard-wearing Mixer T's

Machined out of a single block of high grade machine steel, the hard-wearing Elcometer Mixer T is designed to last.



Serviceable Exhaust T's

When a blast machine exhausts, it can quickly wear out elbow joints, that is why Elcometer Exhaust T's are fitted with sacrificial wear plugs to minimise wear and maximise lifetime.

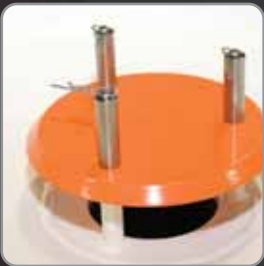

Adjustable Deflector Plates

The adjustable height deflector plate is designed to prevent abrasive escaping the blast machine when the pop up valve is engaged - keeping you safe.



Large Inspection Access

Large, easy to remove access doors to make maintenance easier and faster.



Reinforced Pop Up Valves

The heavy duty internal pop up valve is long lasting and quickly responds to pressurisation.



Narrow & Protected

Designed to fit through most standard doorways, valves and pipework are protected, even when laid down during transportation.



Flexible Pusher Lines

Flexible pusher line ensures air flow without pressure loss caused by elbows.



Air Manifold

The Elcometer Air Manifold allows multiple outlets for ancillary equipment and a pressure relief valve.



Waterproof Sieves & Lids

Optional sieves & lids are designed to fit over the top of the machine to prevent water ingress, keeping the media dry.



Balanced by Design

Easy to manoeuvre on site by one person, no matter their size.



PERFORMANCE

Whether you are blasting at a dockyard or in a blast room, **Elcometer** offers a range of **PERFORMANCE blast machines**, from **0.7 - 10.06cu ft** (20 up to 285 litres), available with **174psi** (12bar) working pressure to maximise productivity.

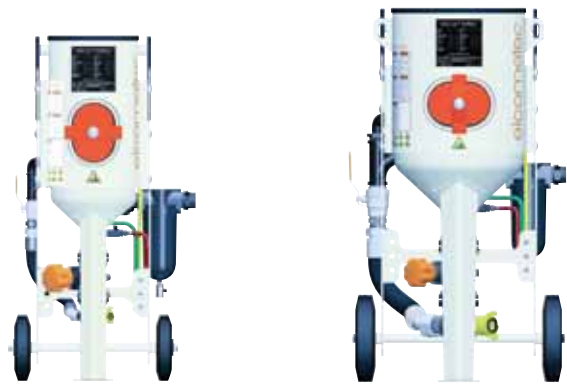

	Options	Elcometer 1020	Elcometer 1440
Capacity	Volume	0.70cu ft (20 litres)	1.41cu ft (40 litres)
	Aluminium Grit	102lbs (47kg)	206lbs (94kg)
	Steel Shot/Garnet	193lbs (88kg)	388lbs (176kg)
Valve Options	GV/MGV: General Valve/ Mini General Valve AGV: Automatic General Valve	MGV	GV AGV
Dimensions	Pot Diameter	10" (254mm)	14" (356mm)
	Height	35" (880mm)	40" (1015mm)
	Width	22" (565mm)	24" (615mm)
	Depth	22" (562mm)	28" (714mm)
	Weight	154lbs (70kg)	209lbs (95kg)



Elcometer PERFORMANCE blast machines are CE approved and fully tested and certified to ASME Boiler and Pressure Vessel Code (BPVC) Section VIII Division 1 with a maximum working pressure of 174psi (12bar).



Elcometer 1460	Elcometer 20100	Elcometer 24200	Elcometer 24285
2.11cu ft (60 litres)	3.53cu ft (100 litres)	7.06cu ft (200 litres)	10.06cu ft (285 litres)
308lbs (140kg)	515lbs (234kg)	1031lbs (468kg)	1469lbs (667kg)
580lbs (264kg)	971lbs (440kg)	1942lbs (880kg)	2767lbs (1254kg)
GV AGV	GV AGV	GV AGV	GV AGV
14" (356mm)	20" (508mm)	24" (610mm)	24" (610mm)
46" (1165mm)	46" (1175mm)	54" (1380mm)	66" (1665mm)
24" (615mm)	28" (704mm)	31" (794mm)	31" (794mm)
28" (714mm)	34" (865mm)	44" (1109mm)	44" (1109mm)
236lbs (107kg)	337lbs (153kg)	452lbs (205kg)	509lbs (231kg)

PERFORMANCE

PERFORMANCE



Kit Selection	Elcometer 1020		Elcometer 1440			
Key Features	Ideal for touch-up applications and spot blasting. Compact, low profile size is easy to fill with abrasive.		Ideal for touch-up applications and spot blasting. Compact size with heavy duty wheels make for easy manoeuvre in small spaces.			
Elcometer Blast Machine Kits are available with:	Kit 1	Kit 2	Kit 1	Kit 2		
Part Numbers	M1020-MGV1-N	M1020-MGV2-N	M1440-GV1-N	M1440-AGV1-N	M1440-GV2-N	M1440-AGV2-N
Abrasive Blast Machine	0.70cu ft (20 litres)		1.41cu ft (40 litres)			
Pressure Test Certificate	●	●	●	●	●	●
RCV4000+ Remote Control Valve with Air Manifold, Exhaust & Silencer	●	●	●	●	●	●
Pneumatic Control Hose & Deadman's Handle (DMHII)	●	●	●	●	●	●
Choke Valve and Pusher Line	●	●	●	●	●	●
Abrasive Metering Valve with Mixer T ¹ and Metal Pot Coupling	MG	MG	G	A	G	A
Moisture Separator	●	●	●	●	●	●
65.6ft (20m) 1¼" (32mm) ID Blast Hose with Cast Iron Hose Couplings & Nylon Nozzle Holder		● ²			●	●
Externally Mounted Sieve and Lid		●			●	●

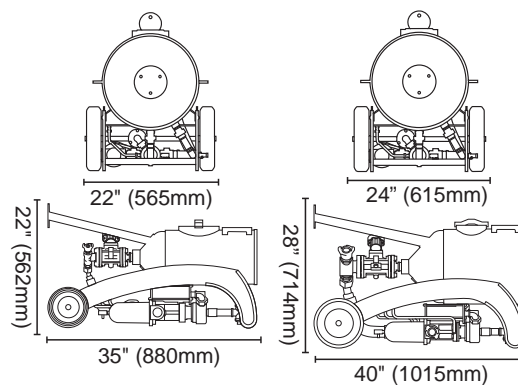

¹ Elcometer 1020 blast machine is supplied with a Flanged T

² Elcometer 1020 blast machine is supplied with a 10m Pneumatic Control Hose and Blast Hose



Elcometer 1460

Elcometer 20100

Elcometer 24200

Elcometer 24285

Ideal for small blast rooms and spot blasting.

Compact size with heavy duty wheels make for easy manoeuvre in small spaces.

Ideal for continuous blasting applications.

Compact size with heavy duty wheels make for easy manoeuvre in small spaces.

Ideal for mobile contractors who need continuous high production blasting as its large capacity reduces down time refilling the hopper.

The twin wheeled portable machine is safe and easy to manoeuvre.

Ideal for continuous high production blasting, on site or in a blast room.

A single blast machine can be used by one or two operators.

The twin wheeled portable machine is safe and easy to manoeuvre.

Kit 1		Kit 2		Kit 1		Kit 2		Kit 1		Kit 2		Kit 1		Kit 2	
M1460-GV1-N	M1460-AGV1-N	M1460-GV2-N	M1460-AGV2-N	M20100-GV1-N	M20100-AGV1-N	M20100-GV2-N	M20100-AGV2-N	M24200-GV1-N	M24200-AGV1-N	M24200-GV2-N	M24200-AGV2-N	M24285-GV1-N	M24285-AGV1-N	M24285-GV2-N	M24285-AGV2-N
2.11cu ft (60 litres)				3.53cu ft (100 litres)				7.06cu ft (200 litres)				10.06cu ft (285 litres)			
•	•	•	•	•	•	•	•	•	•	•	•	•	•	•	•
•	•	•	•	•	•	•	•	•	•	•	•	•	•	•	•
•	•	•	•	•	•	•	•	•	•	•	•	•	•	•	•
•	•	•	•	•	•	•	•	•	•	•	•	•	•	•	•
G	A	G	A	G	A	G	A	G	A	G	A	G	A	G	A
•	•	•	•	•	•	•	•	•	•	•	•	•	•	•	•
		•	•				•			•	•			•	•
		•	•			•	•			•	•			•	•

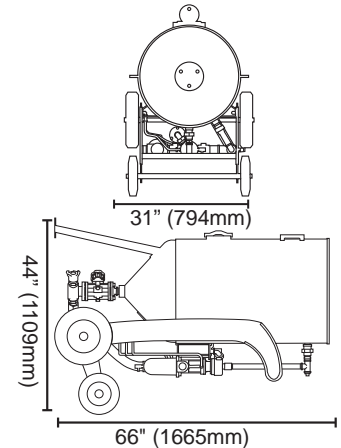
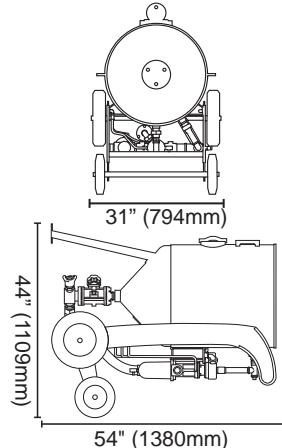
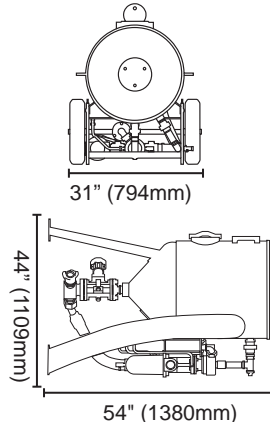
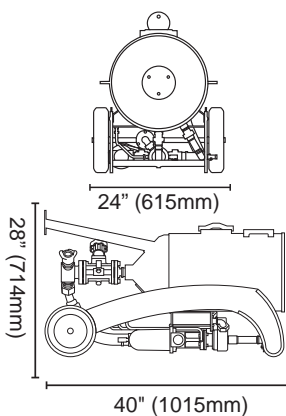

Elcometer 1020 Portable Abrasive Blast Machine

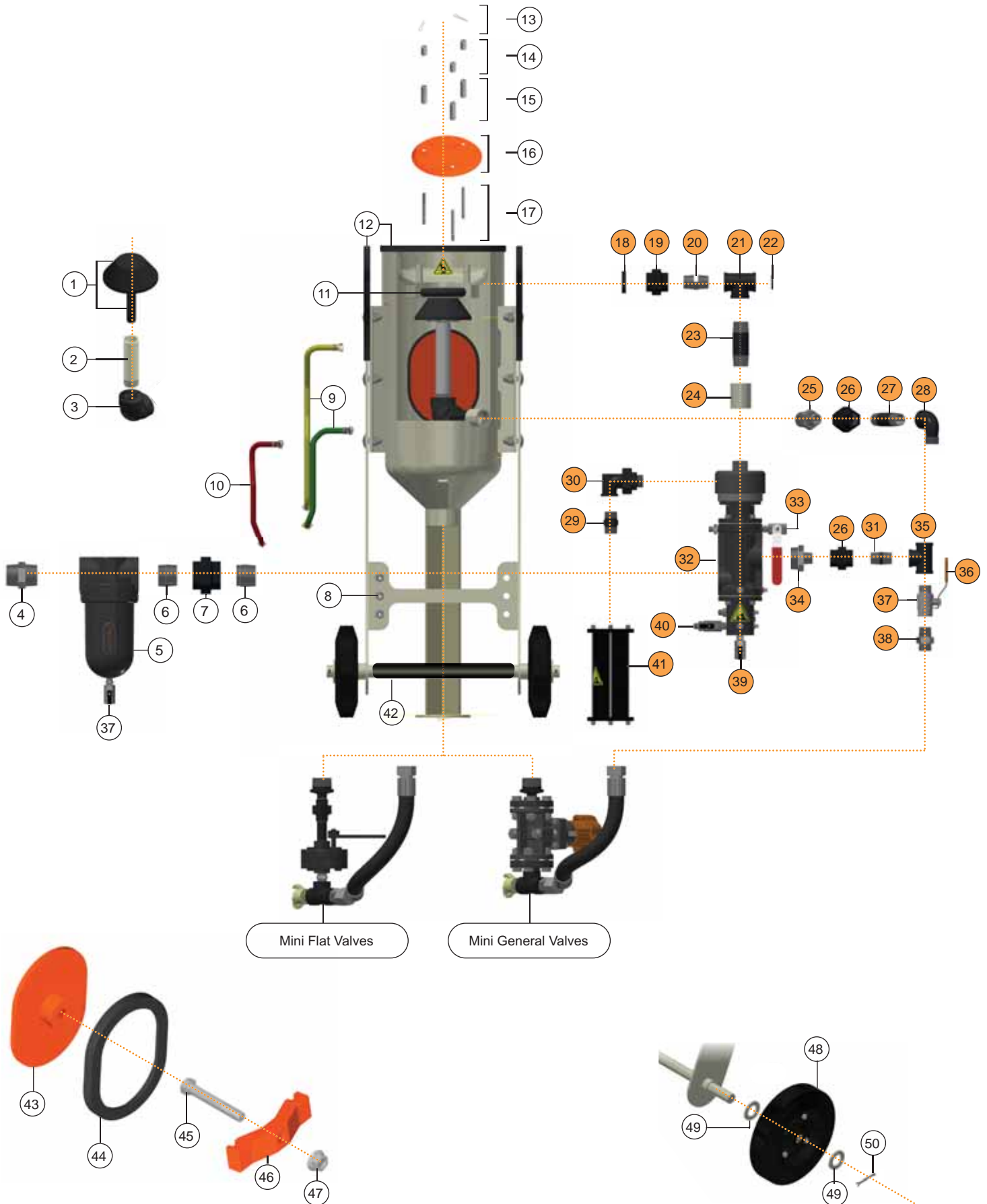

Elcometer 1020 Portable Abrasive Blast Machine

Spare Parts

Item	Part Number	Description
1	MT28622	Pop Up Valve
2	MT28631-1N	1" (25mm) Pop Up Shaft for Elcometer 1020
3	MT29661N	1" (25mm) Female 90° Equal Elbow (Service Item Only)
4	MT31013-3N	1½" (38mm) Hex Nipple
5	MT28617N	Moisture Separator Assembly
6	MT30553-1N	1½" (38mm) Close Nipple
7	MT31018-5N	1½" (38mm) Union Brass Seat
8	MT29664N	¼" (6mm) Bulkhead Connector (x3)
9	MT29665N	Elcometer 1020 Twin Airline Hose Assembly (Yellow & Green)
10	MT29666N	Airline Assembly for Elcometer 1020 (Red)
11	MT28627-5	Pop Up Valve O-Ring (x5)
12	MT29601	Protective Edging Strip Kit 8.9ft (2.7m)
13	MT29667	Spring Cotter Pin Type E (x3)
14	MT29668	Short Deflector Plate Spacer - 0.3" (9mm) (x3)
15	MT29669	Long Deflector Plate Spacer - ¾" (18mm) (x3)
16	MT29670	Deflector Plate
17	MT28629-1	Deflector Plate Shaft - 1.3" (33mm) (x3)
18	MT29672N	1" Backnut
19	MT31018-3N	1" (25mm) Union Brass Seat
20	MT31013-2N	1" (25mm) Hex Nipple
21	MT30574-2N	1" Equal Tee
22	MT29681N	1" (25mm) Solid Plug
23	MT30556-1N	1" (25mm) SCH 40 Pipe Tube
24	MT31017N	1" (25mm) Machine Socket
25	MT30555N	¾" (19mm) x 1" (25mm) Reducing Hex Nipple
26	MT31018-2N	¾" (19mm) Union Brass Seat
27	MT30564-1N	¾" (19mm) Pipe Tube - Length 85mm
28	MT31019-1N	¾" (19mm) Street Elbow 90°
29	MT31013-1N	¾" (19mm) Hex Nipple
30	MT28599N	¾" (19mm) Union Elbow Male
31	MT30564-2N	¾" (19mm) Pipe Tube - Length 1.8" (46mm)
32	MT29465N	Elcometer RCV4000+ Remote Control Valve
33	MT29656N	Petcock Valve Assembly - (Red Handle)
34	MT30554N	¾" (19mm) x 1½" (25mm) Reducing Hex Nipple
35	MT30574-1N	¾" (19mm) Equal Tee
36	MT30095N	¾" (19mm) Choke Valve Handle
37	MT28610N	¾" (19mm) Choke Valve Assembly (includes MT30095N Choke Valve Handle)
38	MT29691N	¾" (19mm) NPTF Male x ⅞" JIC Male Adaptor
39	MT29658N	¼" (6mm) Ball Valve Assembly - (Black Handle)
40	MT29660N	¼" (6mm) Airline Ball Valve Assembly (Black Handle)
41	MT28597N	Exhaust Silencer Assembly
42	MT29692-1	Protection Guard for Elcometer 1020
43	MT29693	Elcometer Inspection Hatch Door for Elcometer 1020
44	MT28613	ElcoFit™ Door Sealing Gasket
45	MT29695N	Elcometer Inspection Door Hatch Bolt - ⅝" x 4⅓" (M16 x 110mm)
46	MT28615	Inspection Hatch Door Yoke
47	MT29696N	⅝" (M16) Hexagon Flanged Nut
48	MT28635	Ø7.9" (200mm) Diameter Wheel (x1)
49	MT29697	Flat Washer (x8)
50	MT29698	Split Cotter Pin (x4)
-	MT29490-1N	Elcometer RCV4000+ & Pipework Assembly Service Kit (contains items in orange)
-	MT29180	Elcometer Safety Label Kit